

# OPERATING INSTRUCTION

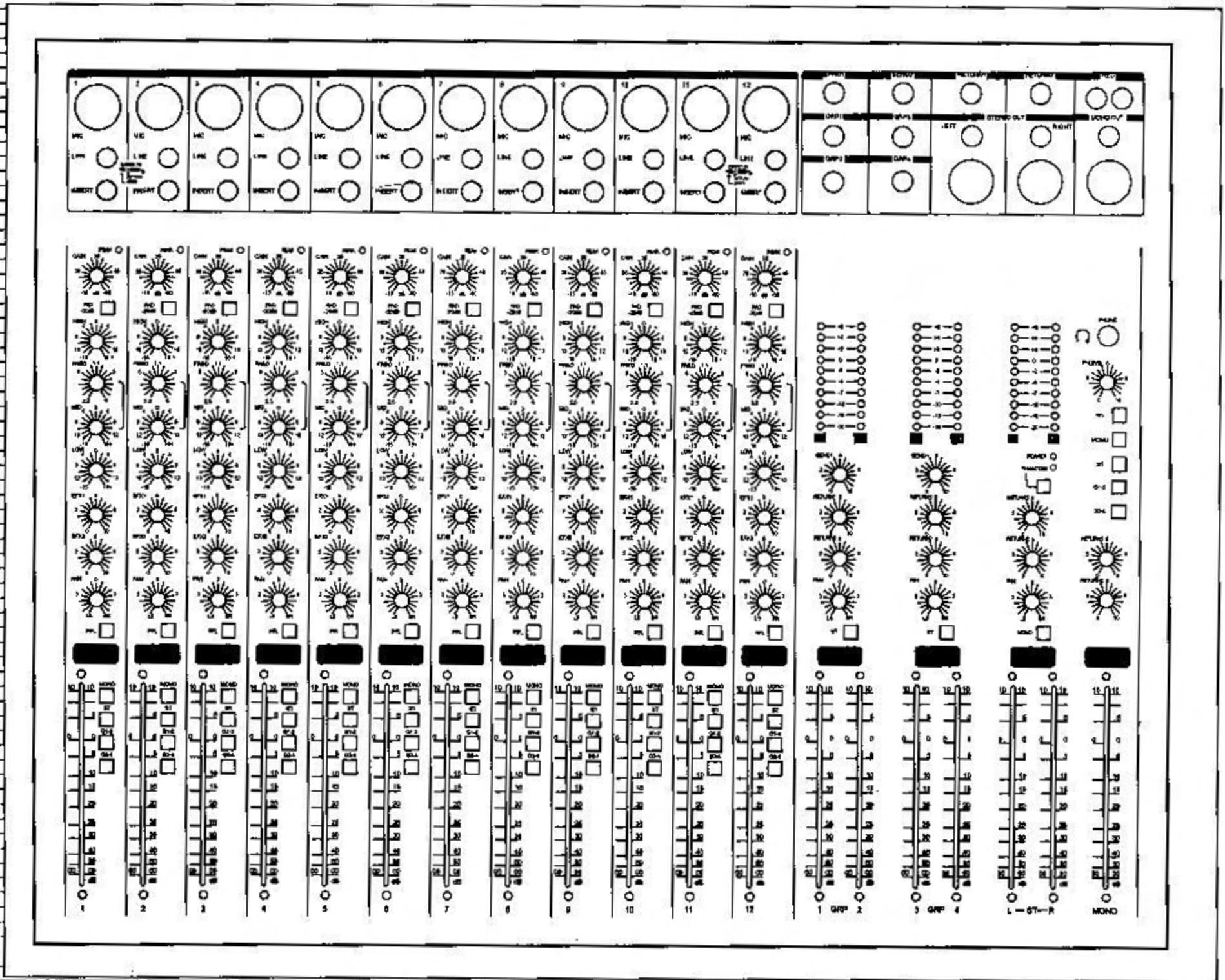

PSX12, PSX16, PSX24

Mixing Consoles Mixers

## CONTENTS

### **FEATURES OF FRONT PANEL**

INPUT CHANNEL SECTION .....	1-2
IGRPS 1-2, 3-4, STEREO, SECTION .....	3-4
PHONE LEVEL, MONO SECTION .....	5
OUTPUT SECTION .....	6
FAULT FINDING GUIDE .....	7
CAUTIONS ON INSTALLATION .....	7
HOW TO OPERATE .....	8
INSTALLATIONS .....	9-11
BLOCK DIAGRAM .....	12

## FEATURES ON FRONT PANEL

### INPUT CHANNEL SECTION

#### 1. BALANCE INPUT

Electronically Balanced inputs acceptable a standard XLR male connector.

+ 48V Phantom Power is available on each input Mic socket. and this switch is on Rear Phantom Power.

#### 2. LINE INPUT

The unbalanced Mic input is provided for the use of a unbalance mic and is designed to accept a unbalanced high impedance input signal.

(This use for connection Deck, Turntable, Keyboard etc..)

#### 3. INSERT

This is used for Tip=Signal output, Ring=Mic Signal input

#### 4. PEAK (PEAK LEVEL INDICATOR)

A red LED indicates a signal level at the insert return point, premaster fader, It illuminates at approximately 5dB below clipping.

#### 5. GAIN CONTROL

Adjusts input sensitivity from -60dB to -20dB with the -20dB pad switch in the out position, and -40dB to 0dB when the -20dB pad switch is pushed.

#### 6. PAD (-20dB)

When pushing this switch, attenuates the input signal -20dB.

#### 7. HIGH

Control the high frequency tone of each channel. Always set this control to the 12 o'clock position, but you can control the high frequency tone according to the speaker, the conditions of listening position and listener's taste. Clockwise rotation of the control increases level.

#### 8.9. FREQUENCY + MID

This equalizer has a "bell" response, i.e. having reached maximum amplification or attenuation at the selected frequency, the amplitude response returns to zero either side of that frequency. The FREQ at which this occurs is variable between 250Hz and 6KHz, The GAIN is variable between  $\pm 15$ dB at the selected frequency with a fixed Q of 1.5. Q is a factor a bandwidth.

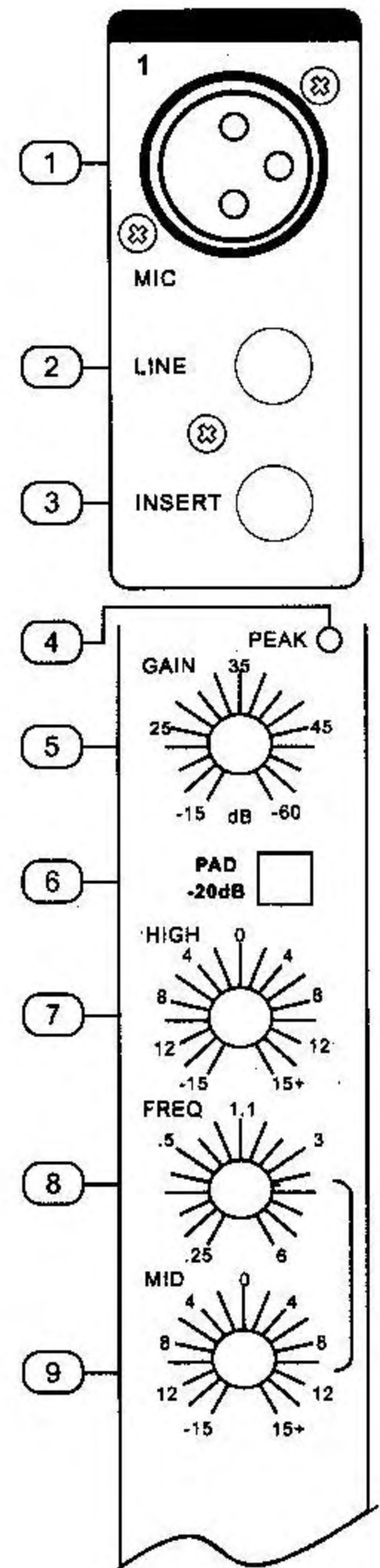

**10. LOW**

Control the low frequency tone of each channel. Always set this control to the 12 o'clock position, but you can control the middle frequency tone according to the speaker, the conditions of listening position and listener's state. Clockwise rotation of the control increase the level.

**11. EFX1**

Use this control to set the level of signal from external stereo source and the main signal control is recontrolled by STEREO or MONO section.

**12. EFX2**

Use this control to set the level of signal from external stereo source and the main signal control is re-controlled by STEREO, MONO, G1-2 or G3-4section.

**13. PAN**

The pan control sends continuous variable amounts of the post fader signal to either the left or right main busses. In the center position equal amounts of signal is sent to the left and right busses.

**14. PFL**

You can monitor the signal of the only channel which PFL switch is turned "ON" using by headphone in useful. When PFL switch turned on, other channels will cut off automatically.

**15. CHANNEL FADER**

This is the function to adjust the volume of signal connection into each channel and adjust the volume of output, together with master fader. Normal operating position is at the "0" mark, providing 4dB of gain above that point, if required.

**16. MONO**

If you want to use MONO fader, push this switch. During the stereo L-R switch pushed, you can't use MONO fader.

**17. STEREO**

Push the switch, can use ST L-R fader. During the stereo L-R switch pushed, you can't use ST L-R fader.

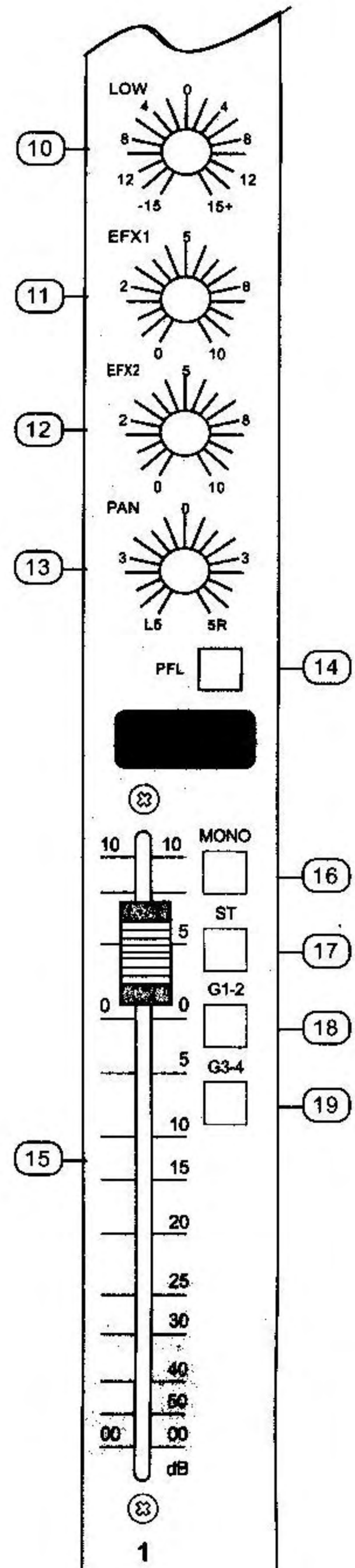

### 18. GRPS 1-2

Push the switch, can use GRPS1-2 fader.

During the G1-2 switch pushed, you can't use stereo L-R fader.

### 19. GRPS 3-4

Push the switch, can use GRPS3-4 fader.

During the G3-4 switch pushed, you can't use stereo L-R fader.

## GRPS 1-2,3-4, STEREO, SECTION

### 20. OUTPUTS LEVEL INDICATOR

This is level meter which shows output levels of left & right channel and GRPS 1-2 & GRPS 3-4 condition on the of operation. Therefore, you can see output condition thru this master level indicator. The LED shows power & phantom is thred " ON " or " OFF " .

### 21. PHANTOM POWERS SWITCH

Depressing this switch applies 48V DC across all microphone input channels connectors for remote powering of condenser microphones.

### 22. EFX1 SEND

When you use G1-2 board, not using STEREO board, you can adjust the sound volume of all kinds of effector outside.

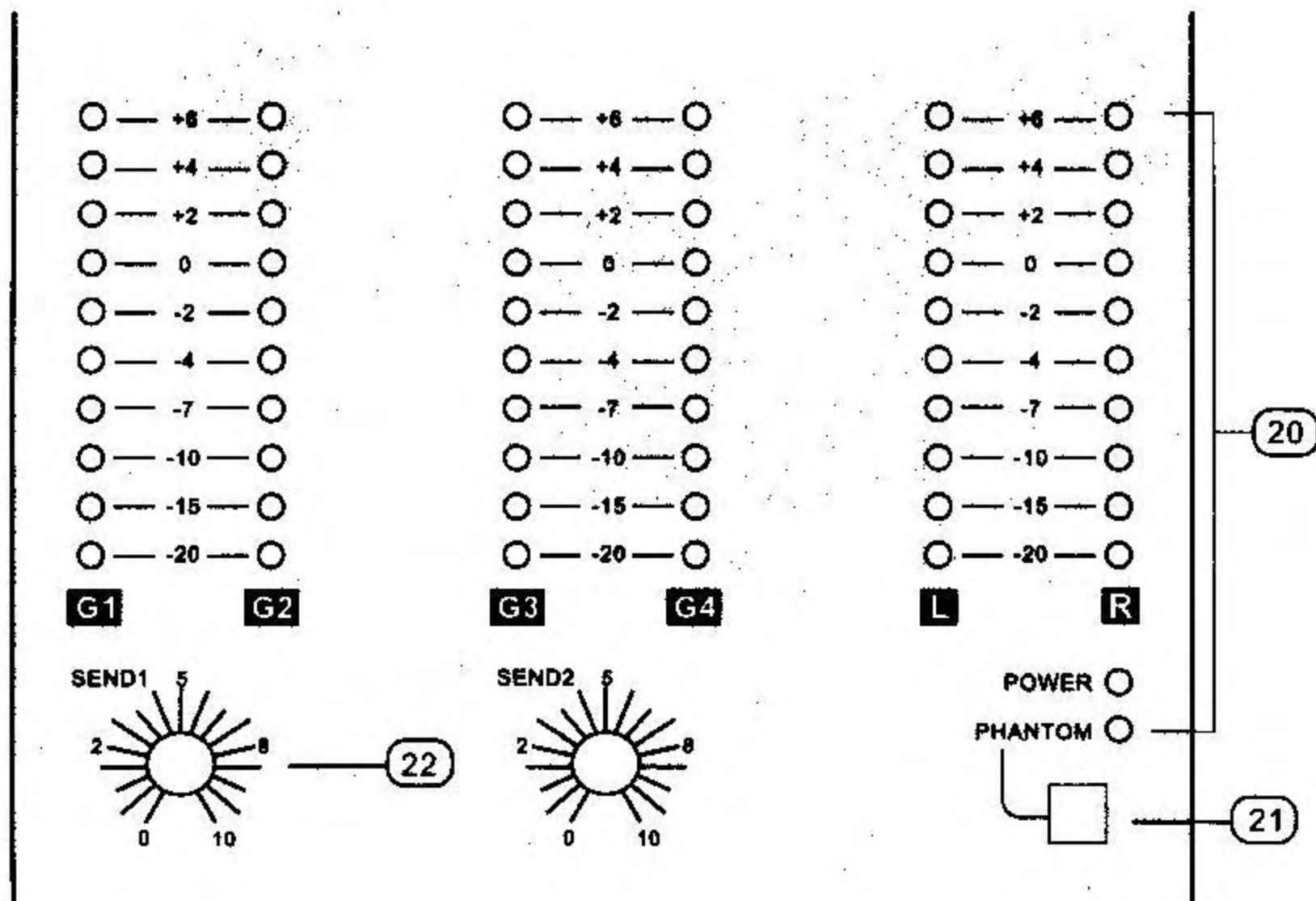

### 23. EFF1,2 RETURN

Controls the G1-2 level of EFF1,2 Input signal.

### 24. PAN

The pan control determines the position of the signal within the GRPS1-2 mix image. Rotation fully counter clockwise the signal solely to the G1 mix buss, while rotation clockwise sweeps the image to the G2 buss.

### 25. ST (STEREO)

When you use G1-2 board, you can select the ON/OFF switch which ST L-R.

### 26. OUTPUT GPRS1-2 FADERAS

Using this control, you can adjust G1, G2 outputs level.

### 27. MONO

When you use STEREO L-R board, you can select the ON/OFF switch which MONO.

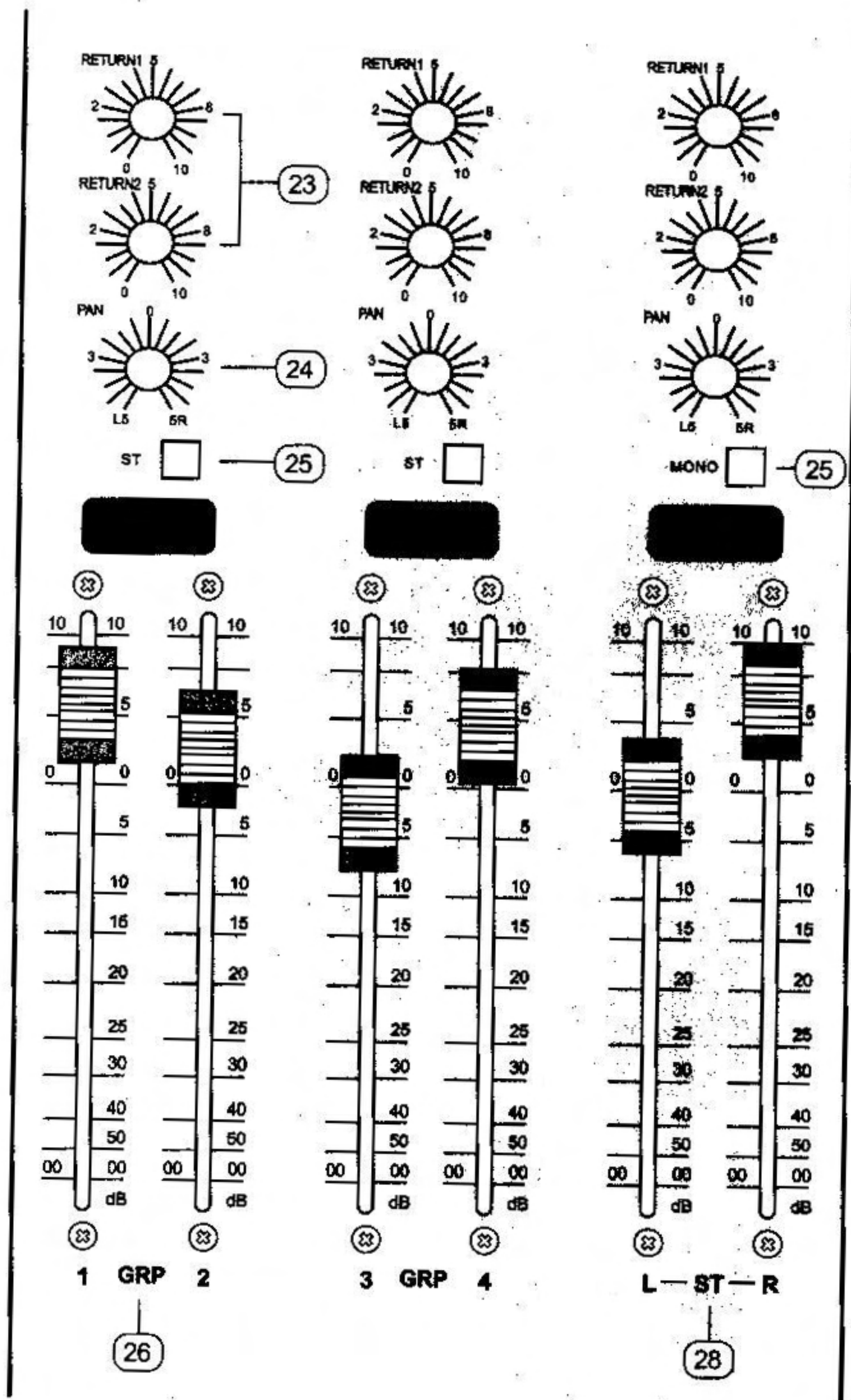

**28. OUTPUT STEREO FADERS (LEFT/RIGHT)**

This is a master fader for adjustment for volume of right/left output. Unity gain is the top of their travel.

**PHONE LEVEL, MONO SECTION**

**29. HEADPHONE JACK**

You can monitor working condition by sound thru the headphone.

**30. HEADPHONE FUNCTION SELECT SWITCH**

The master volume control for the monitor.

**31. HEADPHONE FUNCTION SELECT SWITCH**

When you want PFL, MONO, ST, G1-2, G3-4, you can adjust this control thru headphone.

**32. RETURN 1,2**

Control the MONO level of EFX1,2 Input signal.

**33. OUTPUT MONO FADERS**

Using by this control, you can adjust MONO outputs level.

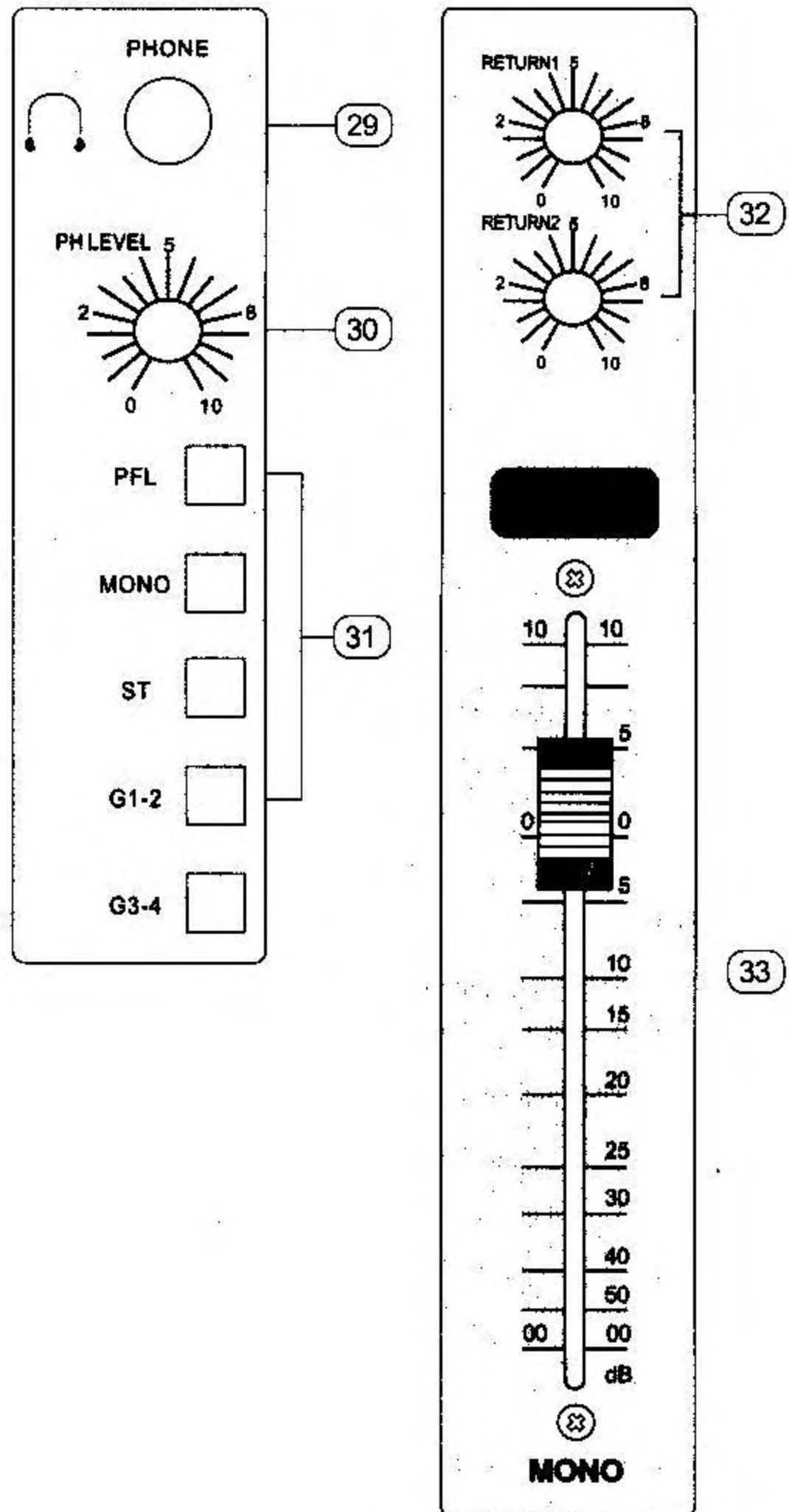

## OUTPUT SECTION

### 34. EFX1,2 SEND, RETURN

This can be used to connect all kinds of effects form outside.

### 35. GPRS1,2,3,4 OUTPUT JACK

The terminal to be output with the volume control against inputting signal into GRPS1, 2,3,4 board.

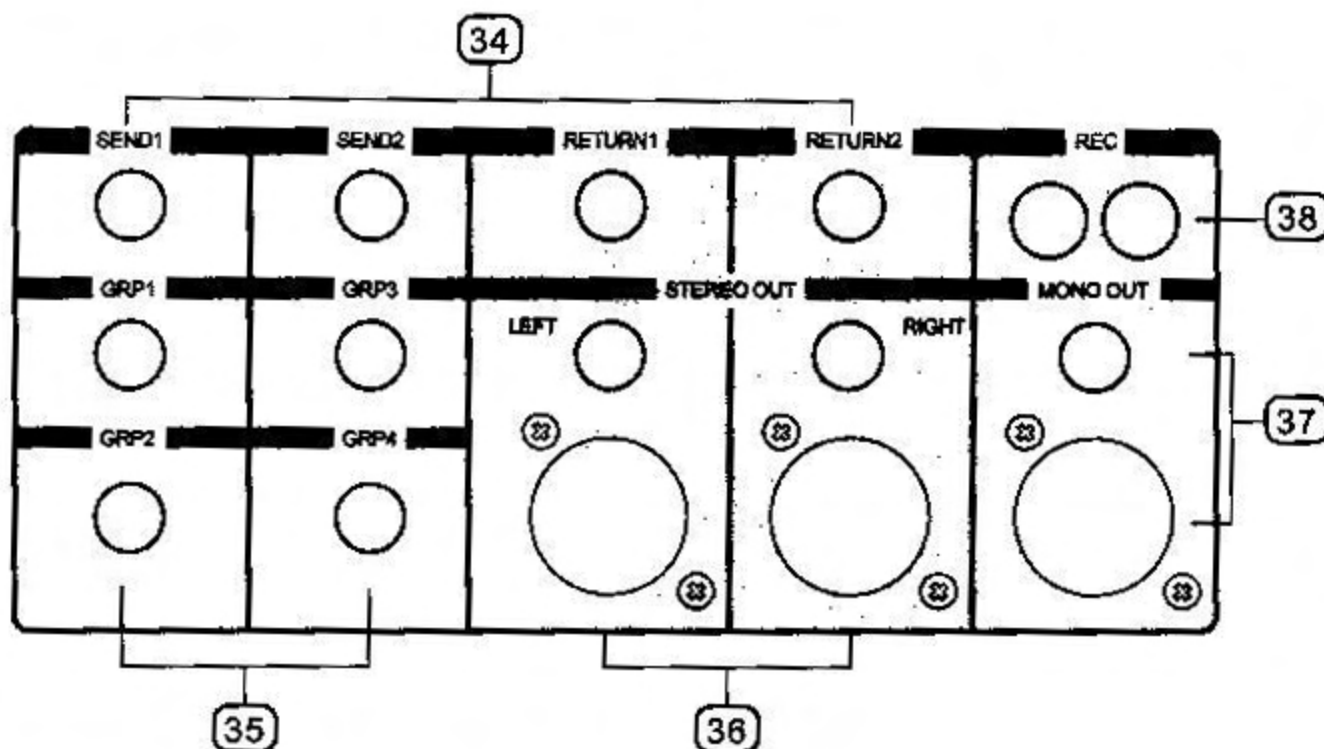

### 36. OUTPUT JACK (LEFT/RIGHT)

In this product, the final confirmed sound can be sent to main amplifier through XLR & 1/4 jack.

### 37. MONO OUT

The terminal to be output with the volume control signal into MONO board.

### 38. REC PIN JACK

This jack is can be connected with cassette desk when recording the mixed.

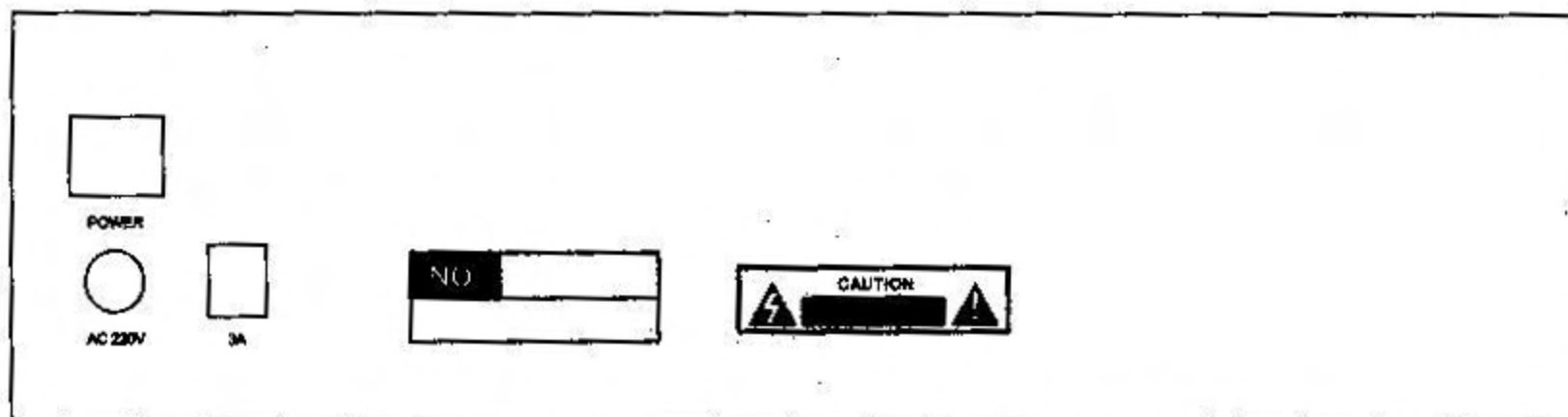

## POWER SECTION

### 39. POWER SWITCH

Push marked (1), when you want to operate, the LED case NO.207 will be turned on when stat working.

### 40. AC POWERED CORD

AC 220~240V 50~60Hz, check the power source of AC 220V before connections.

### 41. FUSE HOLDERS

When occur a problem on this appliance, the fuse will be cut off power to prevent form aproblem.



Repairing a sound mixing console requires specialist, but basic fault finding is within the scope of any user if a few basic rules followed.

- Get to know the Block Diagram of your console.
- Get to know what each component in the system is supposed to do.
- Learn where to look for common trouble spots.

The Block Diagram is a representative sketch of all the components of the console; showing how they connect together and how the signal follows through the system. Once you have become familiar with the various component you have gained a valuable understand of the internal structure of the console and tracking down the problem by elimination.

- Swap input connections to check that the source is really present. Check both Mic and Line inputs.
- Eliminate sections of the channel by using the insert point to re-route the signal to other inputs that are known to be working
- Route channels to different outputs or to auxiliary sends to identify Problems on the master section.
- Compare a suspect channel with an adjustment channel which had been set up identically. Use PFL to monitor the signal in each section.

## **CAUTIONS ON INSTALLATION**

Please take care of the following points for installations.

1. Install this product at place of good ventilation. And keep a interval over 30cm from the other objects.
2. Install this product at rear side for non-touching of somebody, if possible and avoid an installation of a aisle & the front side of the stage.
3. NOT to cause an obstacle and an drop of product from the vibration of speaker, if you put this product on a speaker for a long time.
4. Avoid strong or using product in condition of excessive heat or cold, or in position where it is likely to be subject to vibration, dust or moisture.
5. Connect the plug into an outlet by the check of power source "AC220V" of the installation place.
6. Install the speaker more front side than the used mic and for away from mic, if possible.
7. Insert a plug of cord closely into the speaker jack at the speaker connection.
8. Clean this product with soft dry cloth & poly-wax.

## HOW TO OPERATE:

1. Above all, it is necessary to confirm power voltage.
2. Make sure this appliance power switch is off when connecting the plug of power cord with outlet
3. Set every controls to the positions stated belows to avoid loud blasts. Loud blasts may course damage for your speaker system or your ears when you are wearing headphone. The master faders L-R, Sub faders 1-2, Effect fader & Each channel faders.

Gain control..... Turn to the left completely  
Hi, Freq, Mid, Low ..... Turn to the center position  
EFX 1-2 control ..... Turn to the left completely  
Pan control..... Turn to the center position  
Set other turn to the left completely

4. Push power switch marked(1), then the LED will be turned on when start working.
5. Set Master faders L-R to the position between min & mid, after working.
6. Set a certain Channel faders which you want to use to the position between mini & mid. After that, connect input section with external source.
7. To make sound thru external sources, turn the Gain control to the right.
8. Adjust tone controls in accordance with your taste.

## SPECIFICATION

### MIXER SECTION

1. INPUT CHANNEL SENSITIVITY	MIC.....	-60dB
	STEREO CH. INPUT .....	-40dB
	EFX SEND .....	-20dB
	EFX, RETURN .....	-20dB
	4V MAX -80dB	
2. OUTPUTS	HI.....	$\pm 15\text{dB}/10\text{KHz}$
3. SIGNAL TO NOISE RATIO	MID.....	$\pm 15\text{dB}/250\text{Hz}\sim 6\text{KHz}$
	LOW .....	$\pm 15\text{dB}/60\text{Hz}$

FIGURE 5

UNBALANCED 1/4" PLUG

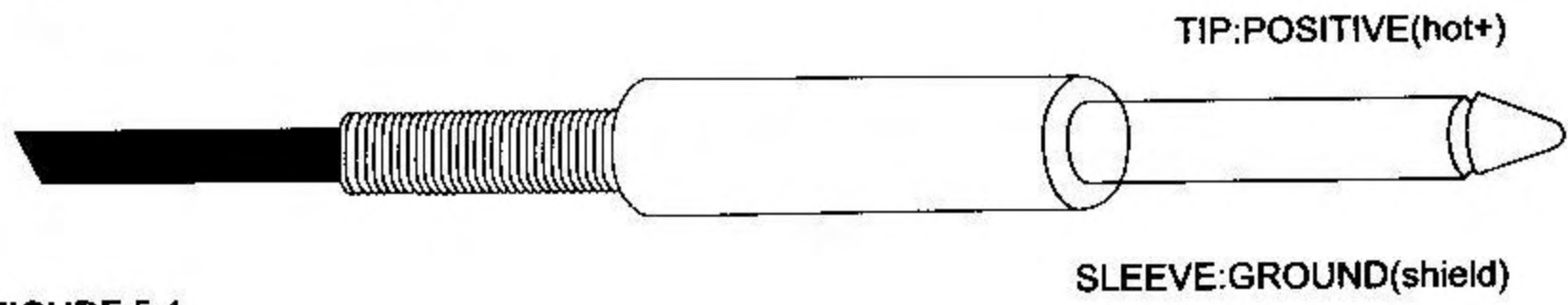

FIGURE 5-1

BALANCED (1/4" STEREO) PLUG

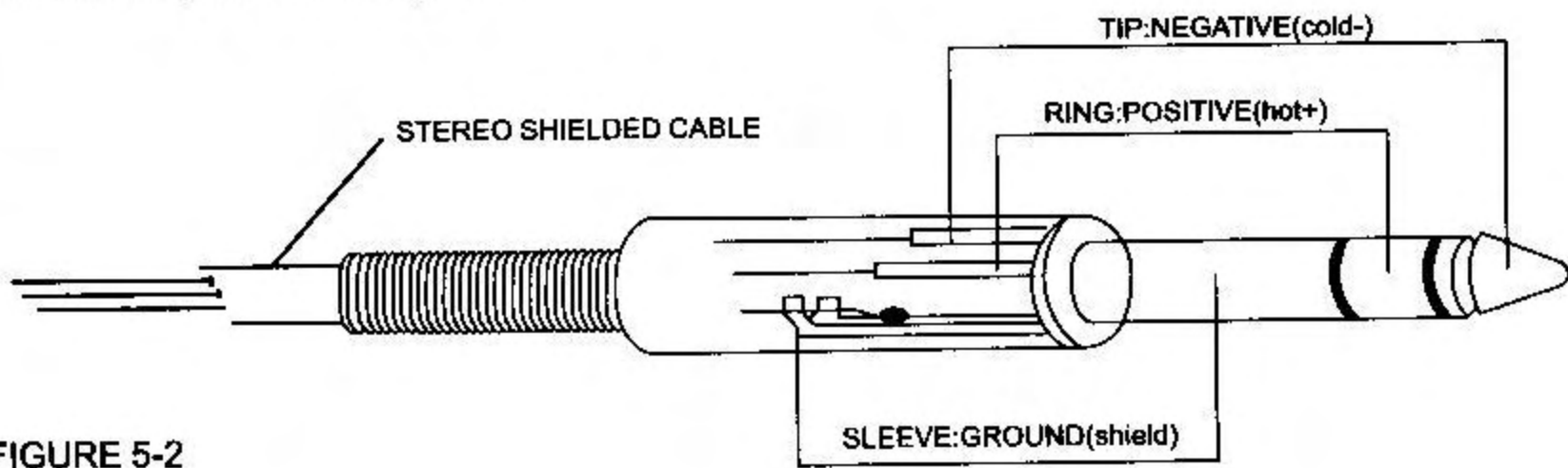
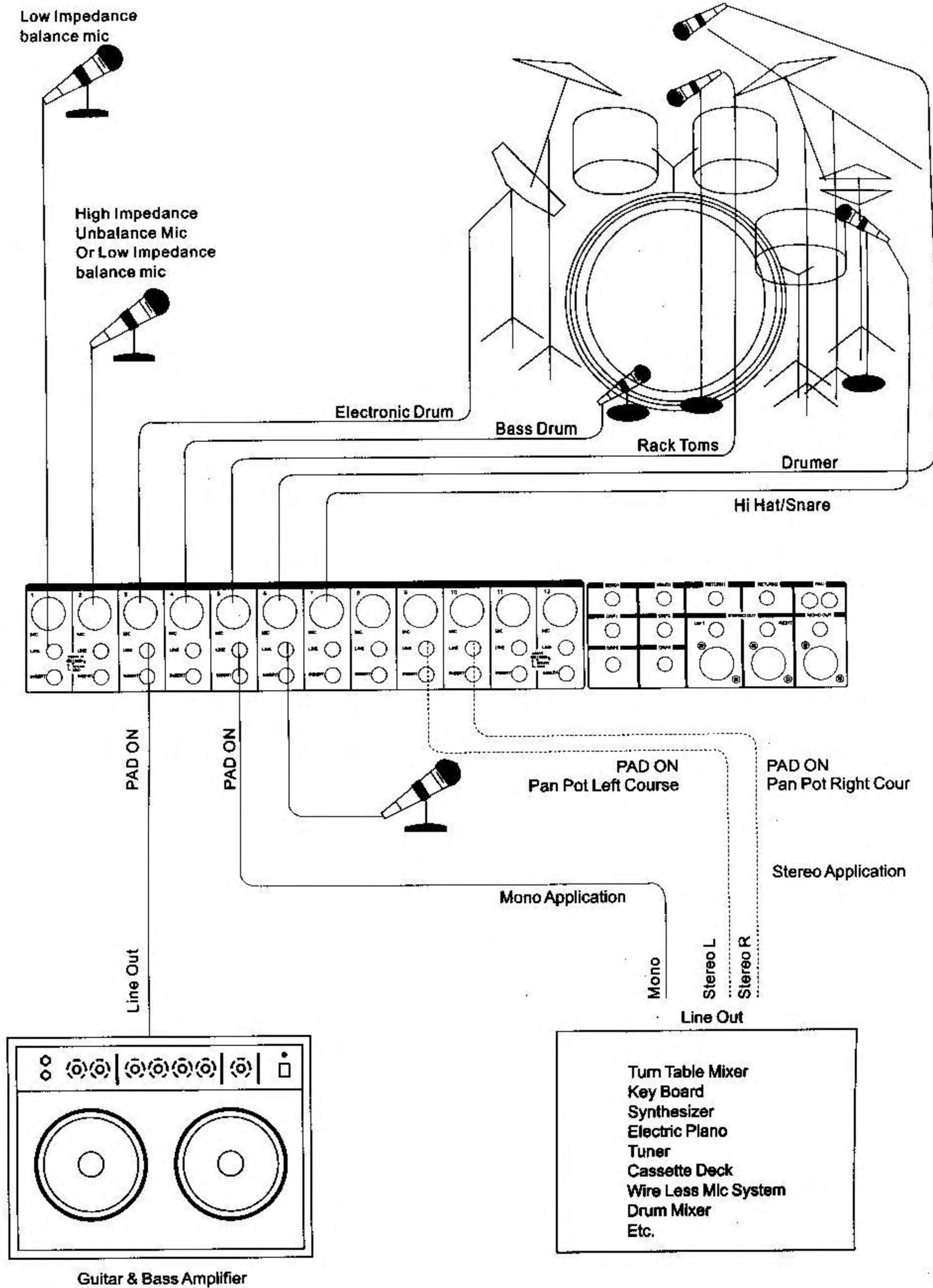

FIGURE 5-2

**INSTALLATIONS**

**FIGURE 1**

**7 BUS MIXING CONSOLE INPUT SYSTEM**



# INSTALLATIONS

FIGURE 2

7 BUS MIXING CONSOLE INPUT SYSTEM

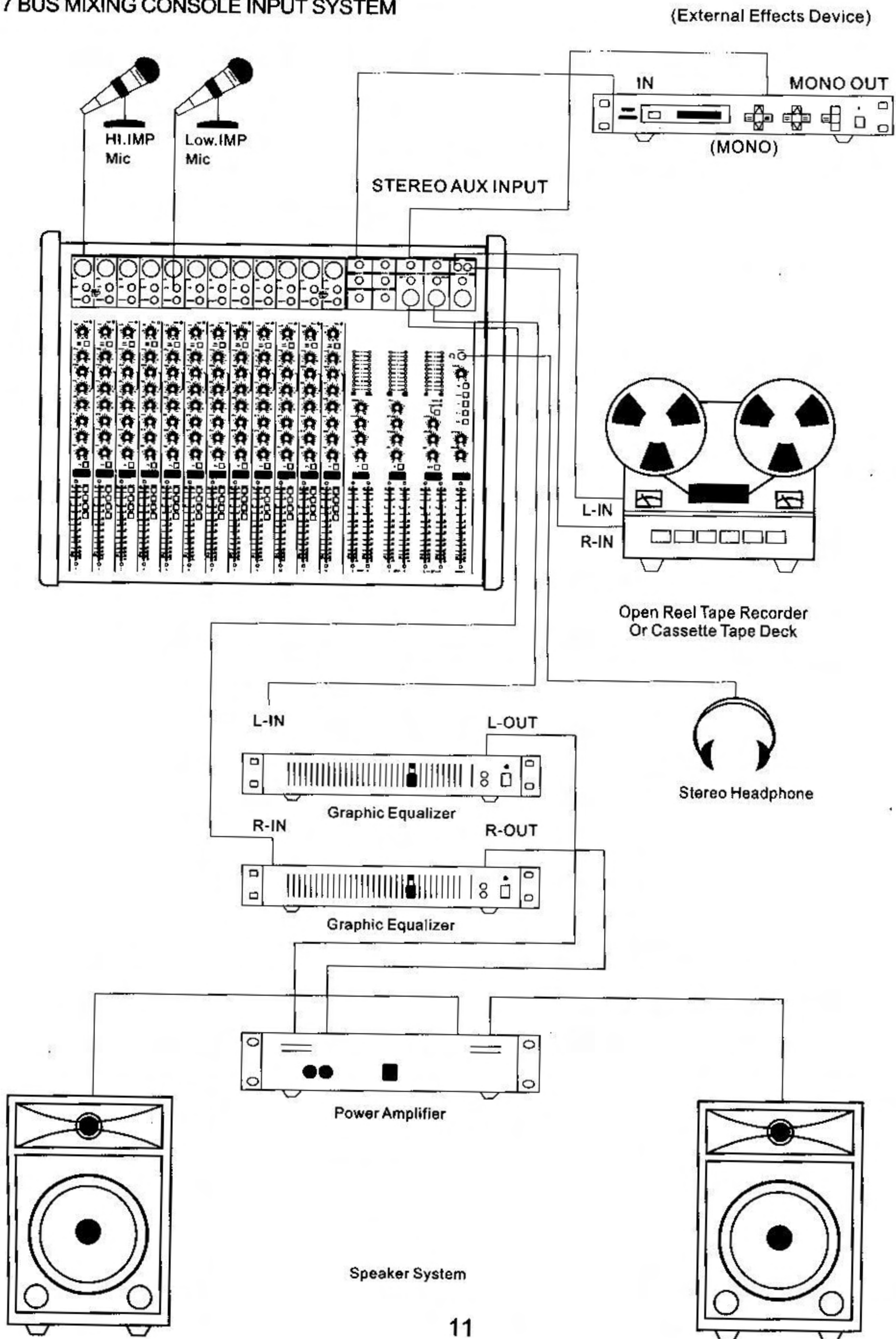

# BLOCK DIAGRAM

